



slp series

**Powerful
Low Profile
Compact**
The SLP Series
rough terrain forklift

 SELICK

Standard specifications

The **low profile** rough terrain SLP Series forklift and the new DieselMax 444 engine powers through rugged outdoor terrain. This **compact** forklift, with its **tight turning radius** & overall small dimensions is designed to work efficiently in close quarters. The drivetrain, a proven performer, will provide years of reliable service.

Engine

DieselMax low noise & emission, four-cylinder, 85 hp, turbocharged diesel engine with fuel/water separator with hand primer, dual element air filter, pre-cleaner, cold weather starting aid & vertical exhaust.

Transmission

Four-speed power reversing synchroshuttle transmission with torque converter and integral parking brake. Optional four-speed fully automatic transmission available.

Axles

High load capacity drive & steer axles provide less wear and low maintenance. Limited slip differential provides increased traction.

Brake system

Enclosed multi-disc, oil-immersed service brakes with independent parking brake, mechanically-operated, lever applied.

Steering

Load sense power steering with hydraulic pump assist.

Instruments

Full instrument package includes warning indicator lights & gauges, horn & backup alarm.

Mast assemblies

Sellick SEE-THRU® all-roller mast design. A wide range of two or three-stage available with maximum lift height up to 22 ft. Sideshift: 6" total.

Standard equipment

- Fully adjustable suspension seat with retractable seatbelt
- Enclosed exhaust system with extra sound insulation in hood
- Hydrostatic steering
- Halogen lighting kit includes two front & two rear worklights
- LED brake & amber flashing lights
- Neutral safety start
- Tilt steering wheel

SLP low profile rough terrain forklift

Lift capacities of 5,000, 6,000 or 8,000 @ 24" load centre

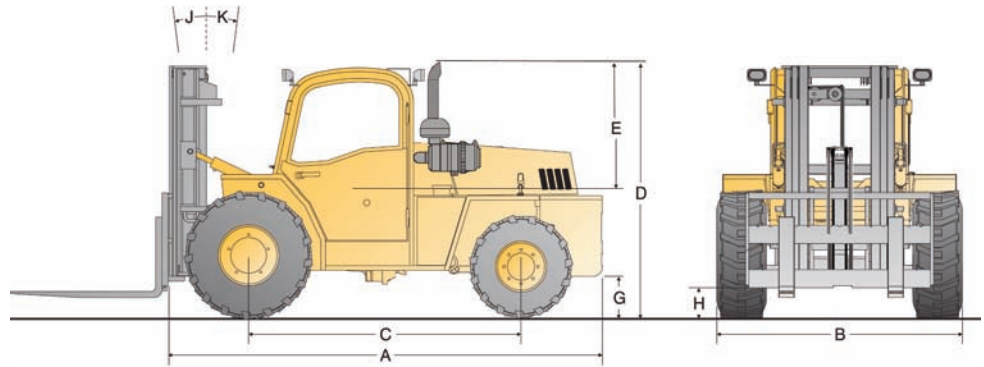

Model	Ref	SLP50	SLP60	SLP80
Lift capacities @ 24 inch load centre		5 000 lbs	6 000 lbs	8 000 lbs
Overall length (without forks)	A		141"/3 581 mm	142"/ 3607 mm
Overall width	B		78"/1 981 mm	
Wheelbase	C		87"/2 210 mm	
Height to top of overhead guard	D		79"/2 007 mm	
Distance from seat to OHG	E		40"/1 016 mm	
Outside turning radius		2WD: 172"/4 369 mm; 4WD: 190"/4 826 mm		
Frame underclearance	G		11"/279 mm	
Mast underclearance	H		12"/203 mm	
Mast sideshift			6"/152 mm	
Mast tilt - forward	J		20°	
Mast tilt - rearward	K		10°	
Gradeability			25%	
Tire size		Drive: 15-19.5-12 ply Steer: 12-16.5-10 ply		
Engine manufacturer & model		DieselMax 444 series turbocharged diesel		
Cylinders		4		
Engine output (gross power)		85 hp @ 2 200 rpm		
Peak torque		267 ft-lbs @ 1 200 rpm		
Weight w/12' mast		11,000 lbs	12,450 lbs	14,400 lbs
Travel speed		15(24) mph(km/h)		

Because of our constant dedication to product improvement, all specifications are subject to change without notice.

— All Sellick forklifts meet or exceed all ANSI B56.6 safety standards. —

SELICK

Sellick Equipment Limited
P.O. Box 1000/358 Erie Street North
Harrow, Ontario, Canada • NOR 1G0
519-738-2255 • sellick@mnsi.net
www.sellickequipment.com

