

NARROW AISLE

Narrow Aisle Reach and Straddle Trucks Electric 24/36 Volt

NPR15D	3,000 lbs 1350 kg
NPR17	3,500 lbs 1600 kg
NPR20	4,000 lbs 1800 kg
NPR22/NSR22	4,500 lbs 2000 kg
NSR25	5,000 lbs 2275 kg

NPR15D/22 NSR22/25

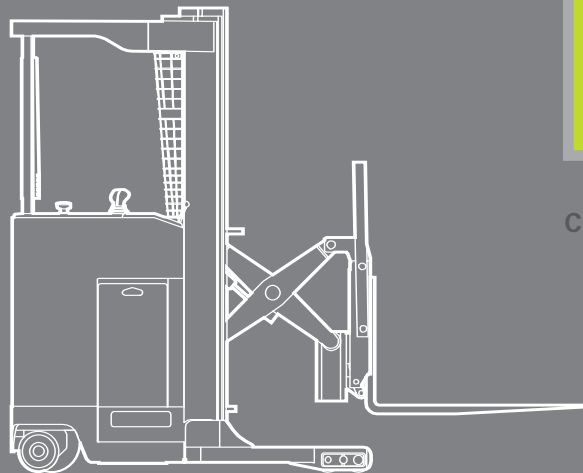

CLARK THE FORKLIFT

North America

Korea

w w w . c l a r k m h c . c o m

For corresponding data see Specification Chart.

DIMENSIONS

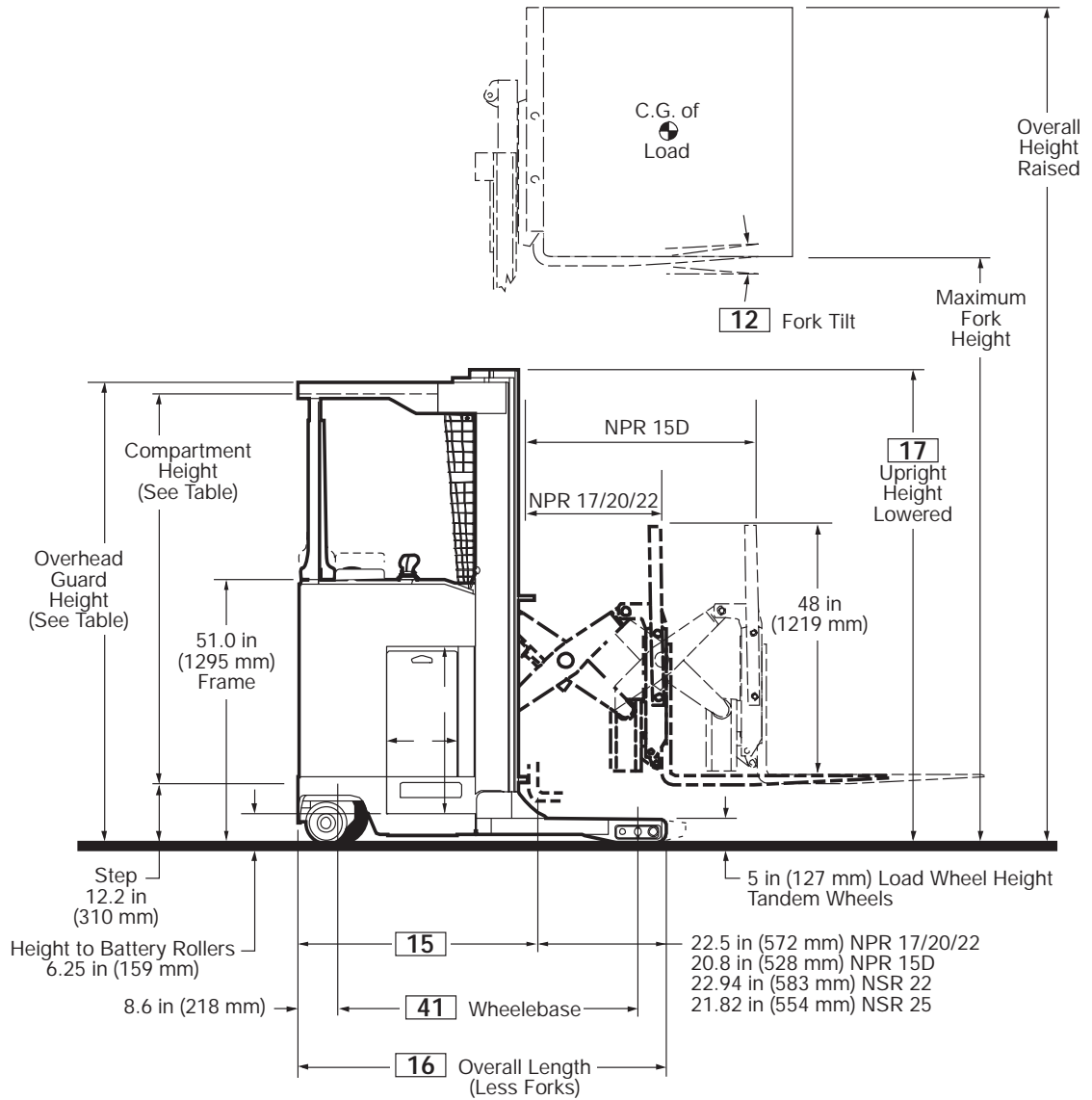

NPR15D/22
NSR22/25

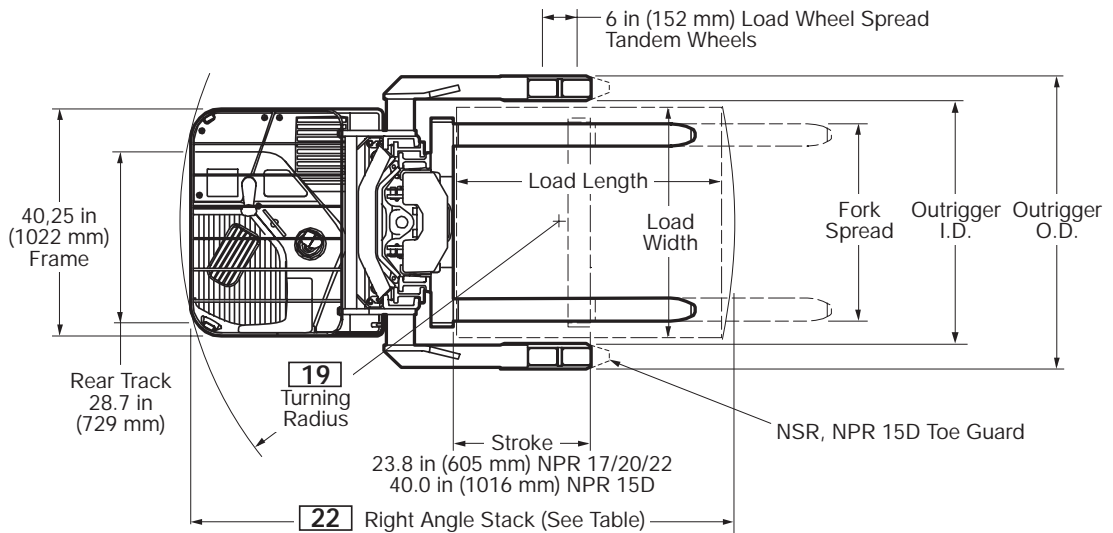

Upright Table

Maximum Fork Height		Overall Height Lowered		Free Lift	
in	mm	in	mm	in	mm
198	5029	89	2261	54	1372
210	5334	95	2413	60	1524
240	6096	107	2718	72	1829
258	6553	113	2870	78	1981
270	6858	119	3023	84	2134
300	7620	131	3327	96	2438
318	8077	139	3531	104	2642
321	8153	139	3531	104	2642
330	8382	149	3785	114	2896
366	9296	161	4089	126	3200

- NPR 15D, NPR 22, NSR 25 only.
- For overall height raised with load backrest, add 48 in (1219 mm) to maximum fork height. Other uprights available, contact Clark representative.

Carriage Widths*/Fork Spread in(mm)

Carriage Width	in	mm	Fork Spread w/o Side Shifter		Fork Spread w/ Side Shifter	
			max	min	max	min
33	838	31.0(787)	13.0(330)	27.7(704)	22.3(566)	
37	940	35.0(889)	13.0(330)	27.7(704)	22.3(566)	

- * 33 in. wide carriage available with outrigger I.D. through 37 in.; 33 or 37 in. wide carriages available with outrigger I.D. 38 in. and greater, 40 in. with 10.5 in. load wheels.

NPR Min. Right Angle Stack Aisle in(mm)*

Pallet or Load Size Length x Width	Battery Compartment (L)			
	13.88(353)	16.13(410)	18.5(470)**	21.0(533)**
36x30(914x762)	82.2(2088)	84.1(2136)	86.8(2205)	89.0(2261)
42x36(1067x914)	87.1(2212)	89.2(2266)	92.1(2339)	94.5(2400)
36x40(914x1016)	82.0(2083)	83.9(2131)	86.8(2205)	89.0(2261)
40x40(1016x1016)	84.8(2154)	86.8(2205)	89.6(2276)	91.9(2334)
48x40(1219x1016)	93.0(2362)	95.1(2416)	98.2(2494)	100.6(2555)
48x42(1219x1067)	92.8(2357)	94.9(2410)	98.0(2489)	100.4(2550)
48x44(1219x1118)	92.6(2352)	94.7(2405)	97.7(2482)	100.2(2545)
48x48(1219x1219)	92.2(2342)	94.3(2395)	97.3(2471)	99.8(2535)

- * Add 6 to 8 inches clearance for ease of operation. Dimensions are based on 42 inch I.D. outrigger with 5 x 3.76 in. load wheels.
- ** Add 8" for NPR 15D (plus operating clearance).

NSR Min. Right Angle Stack Aisle in(mm)*

Pallet or Load Size Length x Width	Battery Compartment (L)			
	13.88(353)	16.13(410)	18.5(470)	21.0(533)
36x30(914x762)	79.7(2024)	81.6(2073)	86.1(2187)	88.3(2243)
42x36(1067x914)	82.3(2090)	84.3(2141)	87.6(2225)	89.8(2281)
36x40(914x1016)	82.0(2083)	83.9(2131)	88.2(2240)	90.4(2296)
40x40(1016x1016)	82.0(2083)	83.9(2131)	88.2(2240)	90.4(2296)
48x40(1219x1016)	89.5(2273)	91.6(2327)	95.1(2416)	97.4(2474)
48x42(1219x1067)	89.1(2263)	91.2(2316)	94.7(2405)	97.1(2466)
48x44(1219x1118)	88.8(2256)	90.9(2309)	94.4(2398)	96.7(2456)
48x48(1219x1219)	88.3(2243)	90.4(2296)	94.0(2388)	96.0(2438)

- * Add 6 to 8 inches clearance for ease of operation. Dimensions are based on I.D. 2" wider than load, 5 x 3.76 load wheels and 7" clearance each side of load.

Grade Clearance

Battery Compartment Width (in/mm)	A%
13.38/340, 13.88/353	15.0%
16.13/410	14.5%
18.5/470	11.6%
21.0/533	10.9%

Outrigger Dimensions - I.D./O.D. (in)

Dual 5 x 3.76 Load Wheels Toe Box Width 140mm		Dual 5 x 3.01 Load Wheels Toe Box Width 114mm		Single 10.5 x 4.5 Load Wheels Toe Box Width 152mm		Dual 4 x 2.62 Load Wheels Toe Box Width 114mm	
I.D.	O.D.	I.D.	O.D.	I.D.	O.D.	I.D.	O.D.
33	44	33	42	-	-	33	42
34	45	34	43	-	-	34	43
36	47	35	44	36.25	48.25	35	44
38	49	37	46	38.25	50.25	37	46
40	51	39	48	40.25	52.25	39	48
41	52	41	50	41.25	53.25	41	50
42	53	42	51	42.25	54.25	42	51
44	55	43	52	44.25	56.25	43	52
46	57	45	54	46.25	58.25	45	54
48	59	47	56	48.25	60.25	47	56
50	61	49	58	50.25	62.25	49	58
-	-	51	60	-	-	51	60

Outrigger Dimensions - I.D./O.D. (mm)

Dual 127 x 96 Load Wheels Toe Box Width 140mm		Dual 127 x 76 Load Wheels Toe Box Width 114mm		Single 267 x 114 Load Wheels Toe Box Width 152mm		Dual 102 x 67 Load Wheels Toe Box Width 114mm	
I.D.	O.D.	I.D.	O.D.	I.D.	O.D.	I.D.	O.D.
838	1118	838	1067	-	-	838	1067
864	1143	864	1092	-	-	864	1092
914	1194	889	1118	921	1226	889	1118
965	1245	940	1168	972	1276	940	1168
1016	1295	991	1219	1022	1327	991	1219
1041	1321	1041	1270	1048	1353	1041	1270
1067	1346	1067	1295	1073	1378	1067	1295
1118	1397	1092	1321	1124	1429	1092	1321
1168	1448	1143	1372	1175	1480	1143	1372
1219	1499	1194	1422	1226	1530	1194	1422
1270	1549	1245	1473	1276	1581	1245	1473
-	-	1295	1524	-	-	1295	1524

Battery Compartment Dimensions

Width (W)		Length (L)		Height (H)	
in	mm	in	mm	in	mm
38.75	984	13.38	340	32.0	813
38.75	984	13.88	353	32.0	813
38.75	984	16.13	410	32.0	813
38.75	984	18.50	470	32.0	813
38.75	984	21.00	533	32.0	813

Maximum Battery Size

Width (W)		Length (L)		Height (H)	
in	mm	in	mm	in	mm
38.69	983	13.00	330	31.5	800
38.69	983	13.50	343	31.5	800
38.69	983	15.75	400	31.5	800
38.69	983	18.00	457	31.5	800
38.69	983	20.50	521	31.5	800

Operator Compartment/ Overhead Guard Dimensions

Maximum Fork Height		Compartment Inside		Overhead Guard Height	
in	mm	in	mm	in	mm
198	5029	75	1905	89	2261
210	5334	81	2057	95	2413
240	6096	81	2057	95	2413
258	6553	81	2057	95	2413
270	6858	81	2057	95	2413
300	7620	81	2057	95	2413
318	8077	81	2057	95	2413
*321	8153	81	2057	95	2413
330	8382	81	2057	95	2413
366	9296	81	2057	95	2413

- *NPR 15D, NPR 22, NSR25 only.

