

POWERWORKERS

Electric 24 Volt Counterbalanced Walkie Straddle

CST10

2200 lbs 1000 kg

CST15

3000 lbs 1365 kg

CST20

4000 lbs 1815 kg

CST10/15/20



CLARK[®]
BUILT TO LAST.[®]

w w w . c l a r k m h c . c o m

DIMENSIONS & DIMENSIONS

General Information			Clark	Clark	Clark
1	Manufacturer		Clark	Clark	Clark
2	Model	Manufacturer's Designation	CST 10	CST 15	CST 20
3	Load capacity	lbs(kg)	2200 (1000)	3000 (1365)	4000 (1815)
4	Load center	Fork face to load CG in(mm)	24 (600)	24 (600)	24 (600)
5	Power Unit	Type	24-volt	24-volt	24-volt
6	Operator Type		Walkie Counterbalanced	Walkie Counterbalanced	Walkie Counterbalanced
7	Tire Type		Poly	Poly	Poly
8	Wheels (x=driven)	Front / rear	2 / 1x	2 / 1x	2 / 1x
Dimensions					
9	Upright	Maximum fork height, full capacity in(mm)	150 (3810)	150 (3810)	118 (2997)
10		Lift height in(mm)	130 (3302)	130 (3302)	130 (3302)
11		Free lift, 2 stage in(mm)	8 (203)	8 (203)	8 (203)
12	Upright tilt	Back/forward degrees	8 / 2	8 / 2	8 / 2
14	Forks	Standard fork size (TxWxL) in(mm)	1.75x4x42 (44x100x1067)	1.75x4x42 (44x100x1067)	1.75x4x42 (44x100x1067)
15	Overall dimensions	Length to fork face in(mm)	65 (1650)	65 (1650)	69.5 (1765)
16		Width in(mm)	38 (970)	38 (970)	38 (970)
17		Height, upright lowered in(mm)	83 (2108)	83 (2108)	83 (2108)
18		Height, upright extended ² in(mm)	178 (4521)	178 (4521)	178 (4521)
19	Turning Radius	in(mm)	58 (1475)	58 (1475)	62.5 (1588)
22	Right angle stack aisle	Add load length and clearance in(mm)	65 (1650)	65 (1650)	69.5 (1765)
Performance					
24	Travel Speeds	Maximum, with load mph(kph)	2.0 (3.0)	1.7 (2.8)	1.6 (2.5)
		Maximum, without load mph(kph)	3.0 (4.8)	3.0 (4.8)	2.6 (4.2)
26	Lift speeds	With load fpm(ms)	39 (0.20)	38 (0.19)	31 (0.16)
		Without load fpm(ms)	59 (0.30)	59 (0.30)	59 (0.30)
	Lower Speed	With load fpm(ms)	34 (0.17)	16 (0.08)	13 (0.07)
		Without load fpm(ms)	25 (0.13)	25 (0.13)	25 (0.13)
Wt					
34	Service Weight	Including minimum battery weight lbs(kg)	4900 (2227)	5400 (2455)	5900 (2682)
Chassis					
39	Tires	Number, front/rear	2 / 1	2 / 1	2 / 1
40		Size, front in(mm)	10.5 x 5 (267 x 125)	10.5 x 5 (267 x 125)	10.5 x 5 (267 x 125)
		Size, rear in(mm)	10 x 4 (255 x 100)	10 x 4 (255 x 100)	10 x 4 (255 x 100)
41	Wheelbase	in(mm)	46.25 (1175)	46.25 (1175)	50.75 (1289)
42	Track	Front in(mm)	31.5 (800)	31.5 (800)	31.5 (800)
44	Ground Clearance	Minimum, with load in(mm)	2.0 (50)	2.0 (50)	2.0 (50)
46	Service Brake	Type	Wet disc	Wet disc	Wet disc
47	Parking Brake	Type	Spring applied	Spring applied	Spring applied
Drive Line					
48	Battery	Type	Lead acid	Lead acid	Lead acid
		Capacity (6 hr. rate) max. kWh	12.2	12.2	12.2
		Weight, minimum lbs(kg)	900 (409)	900 (409)	900 (409)
49	Motors, Controls	Drive motors, dia. in(mm)	6 (152)	6 (152)	6 (152)
		Hydraulic motors, dia. in(mm)	4.75 (121)	4.75 (121)	4.75 (121)
		Drive motor control	Solid state	Solid state	Solid state
		Speed control	Infinitely variable	Infinitely variable	Infinitely variable
		Hydraulic motor control	Solenoid	Solenoid	Solenoid

Notes:
 1. Specifications are given for the truck with 130 in. (3302 mm) standard upright and minimum battery weight.
 2. Includes 48 in. (1219 mm) load backrest height.

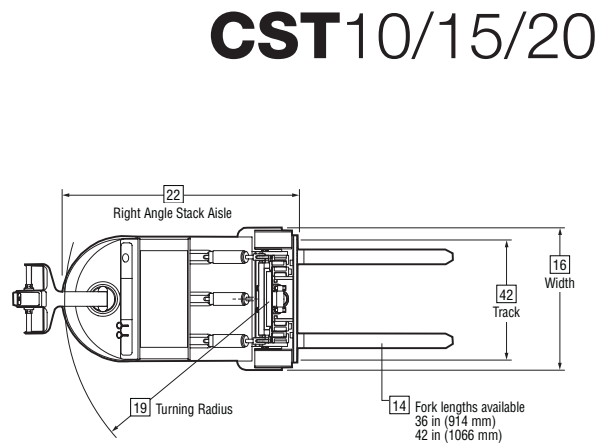
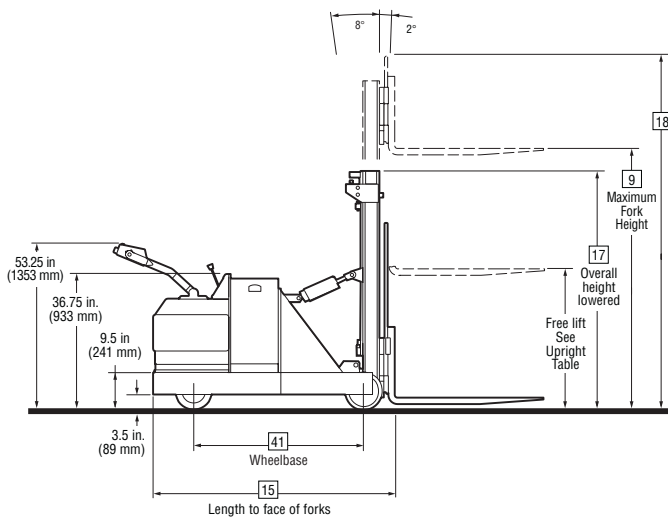

CST10/15/20

Upright Table

Maximum Fork Height		Overall Height Lowered		Free Lift**	
in	mm	in	mm	in	mm
Single Stage					
63	1600	78	1981	63	1600
Two Stage					
118	2997	78	1981	8	203
130	3302	83	2108	8	203
150	3810	93	2362	8	203
Hi-Lo					
130	3302	83	2108	43	1092
Triple Stage					
160	4064	78	1981	8	203
• 172	4368	83	2108	43	1092

- Available on CST15 only.

Battery Compartment Dimensions

For Industrial Battery

Width (W)		Length (L)		Height (H)	
in	mm	in	mm	in	mm
32	810	13.25	336	Open	Open

Performance

Performances are for trucks with 900 lb. (410 kg) industrial battery. Performance may vary +5% or -10% due to motor, tire, drive unit and hydraulic efficiency tolerances and battery weight.

Truck Capacity

Load centers are determined from top and front face of forks. Capacities are based on a 48 in. (1219 mm) cube load configuration with the center of gravity at the center of the cube and standard forks.

Specific capacities are shown on truck nameplates.

Notes

Clark products and specifications are subject to change without notice.

© Clark Material Handling Company 2005.

ANSI/ASME and Insurance Classification

Standard truck meets all applicable mandatory requirements of ASME-B56.1 Safety Standard for Powered Industrial Trucks. For further information contact a Clark representative.

For Your Safety

- Do not operate motorized hand trucks unless you are trained and authorized. Read and understand the operator's manual before operating.
- Do not operate a damaged or faulty truck. Do not attempt repairs unless you are trained and authorized.
- Keep hands on designated grips and feet away from truck. Do not operate truck with wet or greasy hands or shoes.
- Enter confined areas with load end first. Be very careful when operating in confined areas to avoid being pinned.
- Avoid uneven or slippery surfaces and loose materials.
- Travel slowly and with caution on slopes and do not turn. Always travel with load end down grade.
- Do not load truck over capacity on nameplate. Do not handle unstable loads. Be very careful when handling long, high, or wide loads.
- Do not exceed floor weight limits.
- Do not climb or ride on mast or forks.
- Do not allow anyone to stand under raised forks or load.

Contact your Clark dealer for operator training information.

The Clark CST walkie stacker trucks are ideal for use where travel distances are limited. Typical applications include shipping and receiving departments, general distribution and warehousing, grocery and food handling, printing, assembly and soft goods manufacturers.

Control Handle

- Ergonomic design with dual forward/reverse travel controls for thumb or twist operation
- Reversing switch at the end of the handle is spring loaded and designed to override the directional control, automatically reversing the truck on contact
- Brake is actuated by positioning the handle up or down and is automatically applied when handle is released. When the brake is activated, power to the drive unit is cut off

Electrical System

- 24 volt
- Key switch
- Emergency power disconnect button
- Fused drive and control circuits
- High torque drive motor is series wound, fan cooled and has class "H" insulation for maximum protection from heat damage
- Heavy duty motor contactors with replaceable tips

Drive Line

- Sealed gear reducer/brake system with internal multi-disc brakes in oil bath eliminates conventional brake problems such as adjustments, drum and/or shoe replacement
- All gear and brake components protected from exposure to moisture and dirt, packaging, strapping, etc
- All gears are precision ground helical type
- Drive axle mounted on precision-tapered roller bearings

Solid State Speed Controller

- Solid state speed controller with solid state throttle mechanism
- Smooth, stepless acceleration
- Controller programmable to allow custom speed and acceleration settings
- Allows battery efficiency and usage to increase by up to 50% over resistor-controlled units
- Smooth, controlled plugging
- Diagnostic test and fault information

Hydraulic System

- Heavy duty motor, gear pump, check and relief valve
- Lift, lower and tilt functions feature manual lever controls with load feathering capabilities

Upright, Forks and Carriage

- 2° forward, 8° back tilt upright
- Single tilt cylinder on 2200 lb (1000 kg) and 3000 lb (1365 kg) 2 stage unit
- Twin tilt cylinders on 3000 lb (1365 kg) 3 stage and all 4000 lb (1815 kg) units
- Heavy duty nested I-beam upright design
- Bolt-on upright allows for truck to be upgraded if application requirements change
- ITA Class II hook type carriage
- lateral thrust carriage rollers reduce effects of off-center loading
- 42" (1070 mm) forged forks
- Dual leaf style lifting chains with 5:1 safety factor
- 48" (1219 mm) high load backrest

Wheels and Tires

- Press-on 10" x 4", (255 x 100mm) easy steer polyurethane drive tire
- Taper-mounted drive tire hub design for fast easy servicing
- Poly load wheels 10.5" x 5" (267 x 125 mm)

Available Equipment

- 36" and 48" (915 and 1220 mm) long forged forks
- Hour meter
- Hour meter/discharge indicator
- Hour meter/discharge indicator/lift lockout
- UL EE rating
- Handle-installed push button raise, lower and tilt controls
- Sideshifter (up to 150" MFH only)

D
E
S
C
R
I
P
T
I
O
N

 **North America CMHC**
700 Enterprise Drive
Lexington, KY 40510
866-252-5275
www.clarkmhc.com

your authorized CLARK dealer is: