

IC-PNEUMATIC

GEN2™ Series

Pneumatic Tire Lift Trucks LPG/Dual Fuel/Diesel

C20	4,000 lbs 2000 kg
C25	5,000 lbs 2500 kg
C30	6,000 lbs 3000 kg
C35	7,000 lbs 3300 kg

C20/25/30/35



w w w . c l a r k m h c . c o m

For corresponding data see Specification Chart.

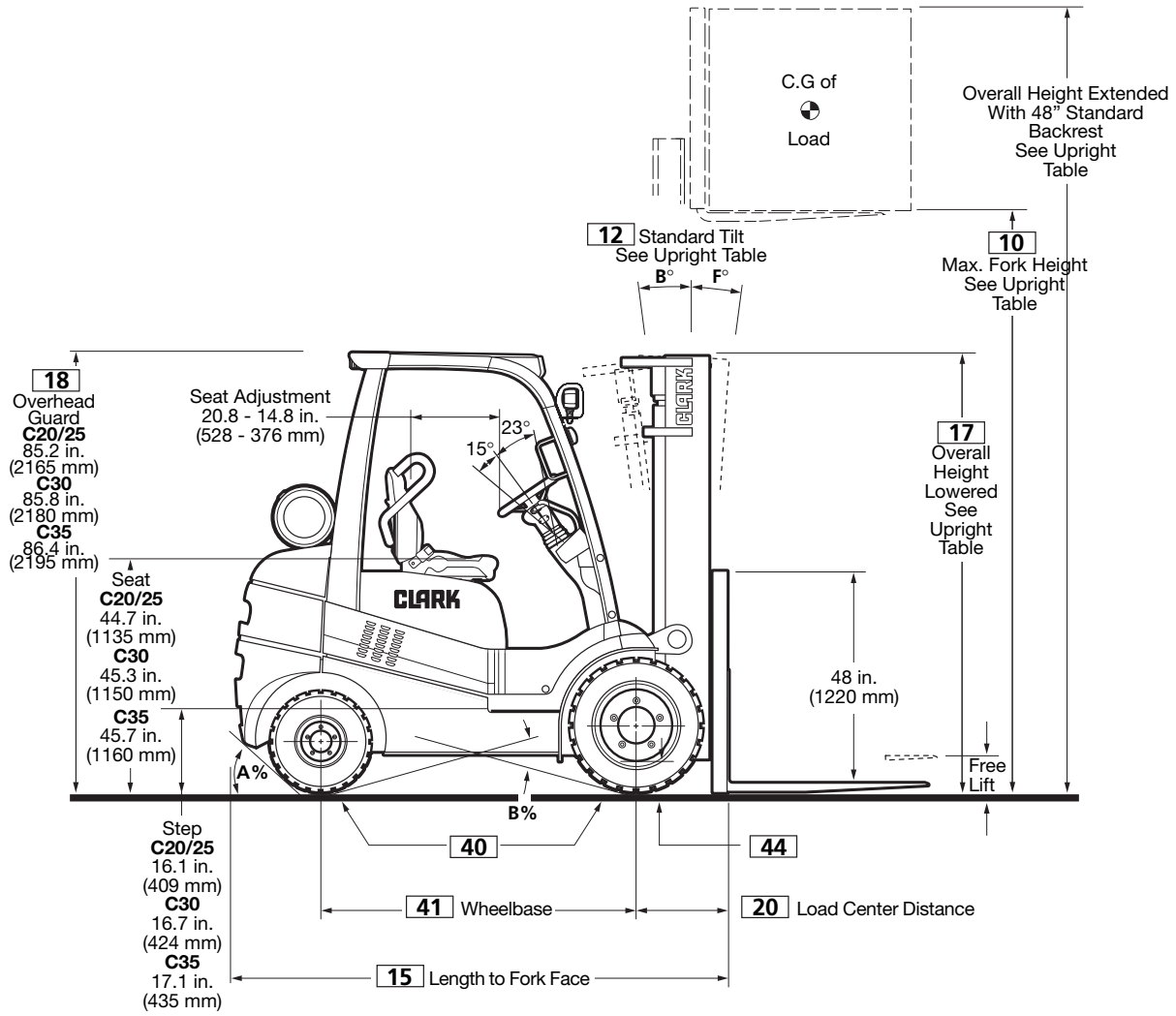

C20/25/30/35

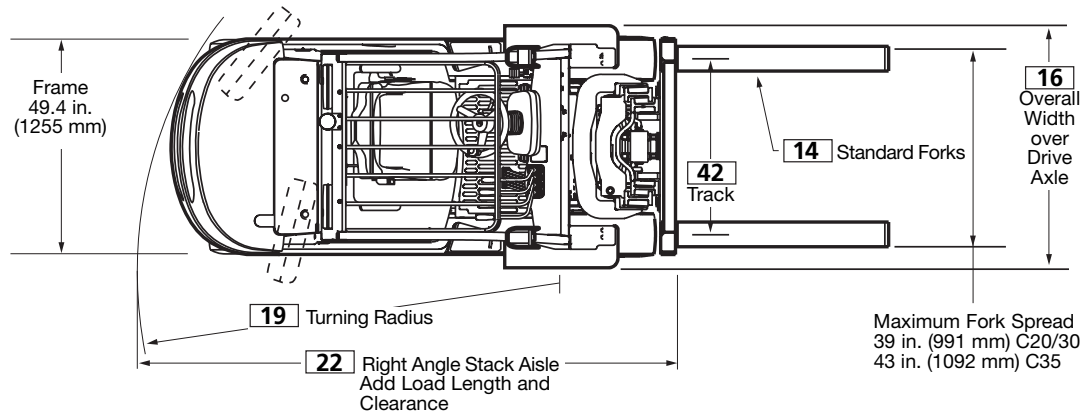

Upright Table

	Maximum Fork Height		Overall Height ¹ Lowered		Free Lift ⁴		Standard Tilt Spec ² B°/F°
	in	mm	in	mm	in	mm	
C20/25 Standard							
83	2110	62.0	1575	4.1	105	6/10	
105	2665	73.0	1854	4.1	105	8/10	
117	2970	78.9	2004	4.1	105	8/10	
•130	3300	85.2	2164	4.1	105	10/8	
146	3705	96.7	2456	4.1	105	10/8	
152	3860	99.6	2529	4.1	105	10/8	
164	4165	110.2	2799	4.1	105	5/6	
172	4380	118.1	2999	4.1	105	5/6	
182	4620	127.2	3230	4.1	105	5/6	
203	5170	137.6	3495	4.1	105	5/3	

C30 Standard							
83	2110	62.6	1590	4.3	110	6/10	
105	2665	73.6	1869	4.3	110	8/10	
117	2970	79.5	2019	4.3	110	8/10	
•130	3300	85.8	2179	4.3	110	10/8	
146	3705	97.2	2468	4.3	110	10/8	
152	3860	100.2	2545	4.3	110	10/8	
164	4165	110.8	2814	4.3	110	5/6	
172	4380	118.7	3014	4.3	110	5/6	
182	4620	127.8	3246	4.3	110	5/6	
203	5170	138.2	3510	4.3	110	5/3	

C35 Standard							
78	1985	63	1610	4.5	115	6/10	
100	2545	74	1890	4.5	115	8/10	
112	2845	80	2040	4.5	115	8/10	
•125	3165	87	2200	4.5	115	10/8	
141	3590	98	2490	4.5	115	10/8	
147	3725	101	2565	4.5	115	10/8	
159	4030	112	2835	4.5	115	5/6	
167	4245	119	3035	4.5	115	5/6	
177	4485	129	3265	4.5	115	5/6	
198	5035	139	3530	4.5	115	5/6	

C20/25 Triple Stage³							
152	3860	73.0	1854	47.3	1201	5/6	
170	4315	78.9	2004	53.2	1351	5/6	
•189	4800	85.2	2164	59.5	1511	5/6	
205	5205	90.7	2303	64.9	1648	5/3	
217	5510	96.7	2456	70.9	1800	5/3	
226	5740	99.6	2529	73.8	1875	5/3	
240	6095	105.9	2689	80.1	2035	5/3	
251	6370	110.2	2799	84.5	2135	3/3	
269	6830	118.1	2999	92.3	2344	3/3	
288	7315	127.2	3230	101.4	2576	3/3	

C30 Triple Stage³							
152	3860	73.6	1869	45.5	1156	5/6	
170	4315	79.5	2019	51.4	1306	5/6	
•189	4800	85.8	2179	57.7	1466	5/6	
205	5205	91.3	2319	63.2	1605	5/3	
217	5510	97.2	2468	69.1	1755	5/3	
226	5740	100.2	2545	72.0	1829	5/3	
240	6095	106.5	2705	78.3	1989	5/3	
251	6370	110.8	2814	82.7	2100	3/3	
269	6830	118.7	3014	90.5	2299	3/3	
288	7315	127.8	3246	99.6	2530	3/3	

C35 Triple Stage³							
146	3680	74	1890	44	1120	5/6	
163	4140	80	2040	50	1270	5/6	
•182	4620	87	2200	57	1450	5/6	
198	5030	92	2340	62	1575	5/6	
210	5340	98	2490	68	1725	5/3	
219	5560	101	2565	71	1805	5/3	
233	5920	107	2725	77	1955	5/3	
243	6190	112	2835	82	2085	5/3	
262	6650	119	3035	89	2260	3/3	
281	7135	129	3265	99	2515	3/3	

C20/25 Hi-Lo							
116	2945	78.9	2004	54.4	1381	8/8	
•128	3250	85.2	2164	60.7	1541	8/8	
139	3531	90.7	2303	66.2	1681	8/8	
148	3760	96.7	2456	72.1	1831	8/8	
154	3912	99.6	2529	75.1	1907	8/8	

Upright Table (cont.)

	Maximum Fork Height		Overall Height ¹ Lowered		Free Lift ⁴		Standard Tilt Spec ² B°/F°
	in	mm	in	mm	in	mm	
C30 Hi-Lo							
116	2945	79.5	2019	52.4	1331	8/8	
•128	3250	85.8	2179	58.7	1491	8/8	
139	3531	91.3	2319	64.2	1631	8/8	
148	3760	97.2	2468	70.1	1781	8/8	
154	3912	100.2	2545	73.1	1857	8/8	

C20/25/30 Quad³							
216	5485	79	2006	53	1346	3/0	
•240	6096	85	2159	59	1499	3/0	
258	6553	91	2311	65	1651	3/0	
276	7010	97	2463	71	1803	3/0	
294	7465	103	2616	77	1955	3/0	
312	7925	109	2769	83	2108	3/0	

Grade Clearance

Model	A%	B%
C20/25	57.7	23.2
C30	57.7	22.9
C35	30.0	25.4

Available Equipment

- Auxiliary valves
- Hose adaptations
- Sideshifters
- Hydraulic control options
- Unitrol foot directional control
- Combination stop/tail/backup lights
- Rear work light
- Turn signal lights
- Strobe lights
- Backup alarm
- Mirrors
- Convenience console
- Suspension seat, vinyl and cloth
- Operator Cab with Heater
- Reduced height overhead guard
- U.L. Type LPS construction
- Seat actuated engine shutdown
- Pre-cleaner – overhead guard mounted
- Air cleaner safety element
- Diesel
- Dual fuel
- CNG
- Travel Speed Limit LPG/Dual Fuel
- Belly Pan
- Radiator screen
- Bottler's tilt
- Tire Options

For Your Safety

Before operating a lift truck, an operator must:

- Be trained and authorized
- Read and understand the operator's manual
- Not operate a faulty lift truck
- Not repair a lift truck unless trained and authorized

- Have the overhead guard and load backrest extension in place

During operation, a lift truck operator must:

- Wear a seat belt
- Keep entire body inside truck cab
- Never carry passengers or lift people
- Keep truck away from people and obstructions
- Travel with lift mechanism as low as possible and tilted back

To park a lift truck, an operator must:

- Completely lower forks or attachments
- Shift into neutral
- Turn key off
- Set parking brake

Contact your Clark dealer for operator training information.

- Indicates preferred common specification.

¹ For overall height raised with load backrest, add 48 in. (1220 mm) to maximum fork height.

² Standard tilt shown. Contact Clark representative for information on optional tilt.

³ Wide track drive tires are standard with uprights 190" (4830 mm) through 247" (6274 mm). Dual drive tires are standard with all quad uprights and other uprights above 247" (6274 mm). Quads require class II carriages, forks and load backrests.

⁴ Freelif dimensions shown are without load backrest.

Other uprights available, contact a Clark representative.

SPECIFICATIONS

General Information	1	Manufacturer		Clark	Clark	Clark	Clark	
	2	Model	Manufacturer's designation	C20L	C25L	C30L	C35L	
	3	Load capacity	lbs(kg)	4000 (2000)	5000 (2500)	6000 (3000)	7000 (3300)	
	4	Load center	Fork face to load CG	in(mm)	24 (500)	24 (500)	24 (500)	24 (500)
	5	Drive unit	Type	LPG	LPG	LPG	LPG	
	6	Operator type		Rider counterbalanced	Rider counterbalanced	Rider counterbalanced	Rider counterbalanced	
	7	Tire type		Pneumatic	Pneumatic	Pneumatic	Pneumatic	
	8	Wheels (x=driven)	Front/rear	2 x / 2	2 x / 2	2 x / 2	2 x / 2	
Basic Dimensions ¹	9	Upright ¹	Maximum fork height, full capacity	in(mm)	170 (4318)	170 (4318)	170 (4320)	146 (3680)
	10		Lift height (preferred triple upright)	in(mm)	189 (4800)	189 (4800)	189 (4800)	182 (4620)
	11		Free lift ¹	in(mm)	59.5 (1511)	59.5 (1511)	57.7 (1466)	57.0 (1448)
	12	Upright tilt	Back/forward (see tilt specifications)	degrees	5B / 6F	5B / 6F	5B / 6F	5B/6F
	14	Fork	Std. Fork size (TxWxD)	in(mm)	1.75x4x42 (45x100x1070)	1.75x4x42 (45x100x1070)	1.75x4.8x42 (45x122x1070)	2.0x4.8x42 (50x122x1070)
	15	Overall dimensions ¹	Length to fork face ¹	in(mm)	98.3 (2496)	100.7 (2558)	105.0 (2668)	109.0 (2770)
	16		Width over drive axle	in(mm)	48.2 (1225)	48.2 (1225)	48.7 (1237)	51.8 (1315)
	17		Height, upright lowered ¹	in(mm)	85.2 (2165)	85.2 (2165)	85.8 (2180)	87.0 (2200)
			Height, upright extended w/ load backrest ¹	in(mm)	237 (6020)	237 (6020)	237 (6020)	230 (5842)
	18		Height, overhead guard	in(mm)	85.2 (2165)	85.2 (2165)	85.8 (2180)	86.4(2195)
	19	Turning radius	Outside	in(mm)	88.4 (2245)	90.6 (2300)	94.7 (2405)	97.6 (2480)
	20	Load center distance ¹	Center of drive axle to fork face ¹	in(mm)	17.9 (455)	17.9 (455)	18.8 (477)	18.7 (475)
	22	Right angle stack aisle ¹	Add load length and clearance ¹	in(mm)	106.3 (2700)	108.5 (2755)	113.5 (2882)	116.3 (2955)
	Performance ^{1,2,3}	23	Stability	According to ANSI B56.1		Yes	Yes	Yes
24		Speed ³	Travel speed, max w/load	mph(kph)	12.5 (20.1)	12.4 (20.0)	12.5 (20.1)	12.6 (20.3)
25			Travel speed, max w/o load	mph(kph)	12.5 (20.1)	12.4 (20.0)	13.2 (21.2)	13.3 (21.4)
		Speed on grade, loaded ³	5%, loaded ³	mph(kph)	11.7 (18.8)	11.4 (18.3)	10.7 (17.2)	9.7 (15.6)
			10%, loaded ³	mph(kph)	10.7 (17.2)	5.2 (8.4)	4.1 (6.6)	3.7 (6.0)
			15%, loaded ³	mph(kph)	6.3 (10.1)	3.1 (5.0)	2.5 (4.0)	2.1 (3.4)
26		Lift speed, loaded/empty ³	Standard upright ¹	fpm(ms)	106/124 (.54/.63)	104/124 (.53/.63)	102/124 (.52/.63)	83/102 (.42/.52)
28			Triple stage upright ¹	fpm(ms)	102/126 (.52/.61)	100/120 (.51/.61)	98/120 (.50/.61)	79/98 (.40/.50)
29		Lower speed, loaded/empty	Standard upright	fpm(ms)	89/89 (.45/.45)	89/89 (.45/.45)	89/89 (.45/.45)	89/89 (.45/.45)
			Triple stage upright	fpm(ms)	85/85 (.43/.43)	85/85 (.43/.43)	85/85 (.43/.43)	85/85 (.43/.43)
30	Drawbar pull, maximum ^{1,3}	With load ¹	lbs/N	4125 / 18350	4125 / 18350	4700 / 20906	4675 / 20795	
32	Gradeability ^{1,3}	At 1 mph (1.6 kph) with load ³	%	26.8	23.1	22.8	17	
		Maximum with/without load ^{1,3}	%	32.6 / 23.3	28.2 / 20.3	29.4 / 19.2	19.0 / 16.4	
Weights ¹	34	Service weight ¹	lbs(kg)	8088 (3669)	8838 (4009)	9786 (4439)	10300 (4672)	
	35	Axle loading ¹	With load, front ¹	lbs(kg)	10885 (4937)	12,386 (5618)	14,213 (6447)	15,138 (6881)
	36		With load, rear ¹	lbs(kg)	1203 (546)	1452 (659)	1573 (713)	2162 (983)
	37		Without load, front ¹	lbs(kg)	4258 (1931)	4101 (1860)	4271 (1937)	3671 (1665)
	38		Without load, rear ¹	lbs(kg)	3830 (1737)	4737 (2149)	5515 (2502)	6629 (3007)
	Chassis	39	Tires	Number, front/rear		2 / 2	2 / 2	2 / 2
40			Size, front	in	7.00x12 - 14PR	7.00x12 - 14PR	8.15x15 - 14PR	250x15-18PR
			Size, rear	in	6.00x9 - 10PR	6.00x9 - 10PR	6.50x10 - 12PR	6.50x10-12PR
41		Wheelbase		in(mm)	63.8 (1620)	63.8 (1620)	66.9 (1700)	66.9 (1700)
42		Track	Front/rear	in(mm)	39.1/35.6 (994/904)	39.1/35.6 (994//904)	40.5/35.9 (1028/912)	41.3/35.9 (1050/912)
44		Ground clearance	Minimum/at center of wheelbase	in(mm)	5.3/6.1 (135/155)	5.3/6.1 (135/155)	5.9/6.5 (150/165)	6.5/6.5 (165/165)
46		Service brake	Type		Drum	Drum	Drum	Drum
47		Parking brake	Actuation		Foot	Foot	Foot	Foot
	Steering	Type		Hydrostatic	Hydrostatic	Hydrostatic	Hydrostatic	
Drive Line	49	Engine ^{3,4}	Manufacturer/model		Mitsubishi / 4G64	Mitsubishi / 4G64	Mitsubishi / 4G64	Mitsubishi / 4G64
	51		Rated output ⁴	HP/kW@rpm	47.5 / 35.4 @ 2250	47.5 / 35.4 @ 2250	47.5 / 35.4 @ 2250	47.5 / 35.4 @ 2250
			Torque ⁴	Lb-ft/Nm@rpm	120 / 163 @ 1400	120 / 163 @ 1400	120 / 163 @ 1400	120 / 163 @ 1400
	52		Speed, max governed	rpm	2650	2650	2650	2650
	53		Cylinders/displacement	cu. in.-liters	4 / 143 - 2.4	4 / 143 - 2.4	4 / 143 - 2.4	4 / 143 - 2.4
	54	Transmission	Manufacturer/type, speeds F/R		Clark/Powershift, 1/1	Clark/Powershift, 1/1	Clark/Powershift, 1/1	Clark/Powershift, 1/1
57	Hydraulic pressure	For attachments	PSI/Bar	Adjustable	Adjustable	Adjustable	Adjustable	
58	Sound level	Avg. at operator's ear per ISO	dB(A)	78	78	78	78	

- Notes:**
- 1 Weights and performance information are given on trucks with 189 in. (4800 mm) triple uprights (182 in (4625 mm) on C35).
 - 2 Performance information shown for LPG.
 - 3 Engines rated per SAE J1349.

General Information	1	Manufacturer		Clark	Clark	Clark	Clark
	2	Model	Manufacturer's designation	C20D	C25D	C30D	C35D
	3	Load capacity	lbs(kg)	4000 (2000)	5000 (2500)	6000 (3000)	7000 (3300)
	4	Load center	Fork face to load CG in(mm)	24 (500)	24 (500)	24 (500)	24 (500)
	5	Drive unit	Type	Diesel	Diesel	Diesel	Diesel
	6	Operator type		Rider counterbalanced	Rider counterbalanced	Rider counterbalanced	Rider counterbalanced
	7	Tire type		Pneumatic	Pneumatic	Pneumatic	Pneumatic
	8	Wheels (x=driven)	Front/rear	2 x / 2	2 x / 2	2 x / 2	2 x / 2
Basic Dimensions ¹	9	Upright ¹	Maximum fork height, full capacity in(mm)	170 (4320)	170 (4320)	170 (4320)	146 (3680)
	10		Lift height (preferred triple upright) in(mm)	189 (4800)	189 (4800)	189 (4800)	182 (4620)
	11		Free lift ¹ in(mm)	59.5 (1511)	59.5 (1511)	57.7 (1466)	57.0 (1448)
	12	Upright tilt	Back/forward (see tilt specifications) degrees	5B / 6F	5B / 6F	5B / 6F	5B / 6F
	14	Fork	Std. Fork size (TxWxL) in(mm)	1.75x4x42 (45x100x1070)	1.75x4x42 (45x100x1070)	1.75x4.8x42 (45x122x1070)	2.0x4.8x42 (50x122x1070)
	15	Overall dimensions ¹	Length to fork face ² in(mm)	98.3 (2496)	100.7 (2558)	105.0 (2668)	109.0 (2770)
	16		Width over drive axle in(mm)	48.2 (1225)	48.2 (1225)	48.7 (1237)	51.8 (1315)
	17		Height, upright lowered ² in(mm)	85.2 (2165)	85.2 (2165)	85.8 (2180)	87.0 (2200)
			Height, upright extended w/ load backrest ² in(mm)	237 (6020)	237 (6020)	237 (6020)	230 (5842)
	18		Height, overhead guard in(mm)	85.2 (2165)	85.2 (2165)	85.8 (2180)	86.4 (2195)
	19	Turning radius	Outside in(mm)	88.4 (2245)	90.6 (2300)	94.7 (2405)	97.6 (2480)
	20	Load center distance ¹	Center of drive axle to fork face ² in(mm)	17.9 (455)	17.9 (455)	18.8 (477)	18.7 (475)
22	Right angle stack aisle ¹	Add load length and clearance ² in(mm)	106.3 (2700)	108.5 (2755)	113.5 (2882)	116.3 (2955)	
Performance ^{1,2,3}	23	Stability	According to ANSI B56.1	Yes	Yes	Yes	Yes
	24	Speed ³	Travel speed, max w/load mph(kph)	12.0 (19.3)	12.0 (19.3)	12.7 (20.5)	13.0 (21)
	25		Travel speed, max w/o load mph(kph)	12.7 (20.4)	12.7 (20.4)	13.3 (21.4)	13.4 (21.5)
		Speed on grade, loaded ³	5%, loaded ² mph(kph)	11.1 (17.8)	10.8 (17.4)	11.5 (18.5)	11.9
			10%, loaded ² mph(kph)	9.9 (15.9)	6.8 (11.0)	5.5 (8.9)	6.1
			15%, loaded ² mph(kph)	5.2 (8.4)	4.5 (7.2)	3.7 (5.9)	3.6
	26	Lift speed, loaded/empty ³	Standard upright ² fpm(ms)	110/128 (.56/.65)	108/128 (.55/.65)	106/128 (.54/.65)	94.5/124 (.48/.63)
	28		Triple stage upright ² fpm(ms)	106/124 (.54/.63)	104/124 (.53/.63)	102/124 (.52/.63)	90.6/120 (.46/.61)
	29	Lower speed, loaded/empty	Standard upright fpm(ms)	89/89 (.45/.45)	89/89 (.45/.45)	89/89 (.45/.45)	89/89 (.45/.45)
			Triple stage upright fpm(ms)	85/85 (.43/.43)	85/85 (.43/.43)	85/85 (.43/.43)	85/85 (.43/.43)
30	Drawbar pull, maximum ^{1,3}	With load ² lbs/N	5209 / 23,170	5348 / 23,790	4640 / 20,640	4634/20,613	
32	Gradeability ^{1,3}	At 1 mph (1.6 kph) with load ² %	42.3	36.1	28.5	20.5	
		Maximum with/without load ^{1,3} %	46.2 / 27.1	40.4 / 23.8	29.1 / 22.9	25.8/17.4	
Weights ¹	34	Service weight ¹	lbs(kg)	8088 (3669)	8838 (4009)	9786 (4439)	11,014 (4996)
	35	Axle loading ¹	With load, front ² lbs(kg)	10885 (4937)	12,386 (5618)	14,213 (6447)	15,759 (7163)
	36		With load, rear ² lbs(kg)	1203 (546)	1452 (659)	1573 (713)	2,255 (1025)
	37		Without load, front ² lbs(kg)	4258 (1931)	4101 (1860)	4271 (1937)	4,292 (1947)
	38		Without load, rear ² lbs(kg)	3830 (1737)	4737 (2149)	5515 (2502)	6,722 (3049)
Chassis	39	Tires	Number, front/rear	2 / 2	2 / 2	2 / 2	2 / 2
	40		Size, front in	7.00x12 - 14PR	7.00x12 - 14PR	8.15x15 - 14PR	250x15-18PR
			Size, rear in	6.00x9 - 10PR	6.00x9 - 10PR	6.50x10 - 12PR	6.50x10 - 12PR
	41	Wheelbase	in(mm)	63.8 (1620)	63.8 (1620)	66.9 (1700)	66.9 (1700)
	42	Track	Front/rear in(mm)	39.1/35.6 (994/904)	39.1/35.6 (994/904)	40.5/35.9 (1028/912)	41.3/35.9 (1050/912)
	44	Ground clearance	Minimum/at center of wheelbase in(mm)	5.3/6.1 (135/155)	5.3/6.1 (135/155)	5.9/6.5 (150/165)	6.5/6.5 (165/165)
	46	Service brake	Type	Drum	Drum	Drum	Drum
	47	Parking brake	Actuation	Foot	Foot	Foot	Foot
	Steering	Type	Hydrostatic	Hydrostatic	Hydrostatic	Hydrostatic	
Drive Line	49	Engine ^{3,4}	Manufacturer/model	Yanmar 4TNV94	Yanmar 4TNV94	Yanmar 4TNV94	Yanmar 4TNV94
	51		Rated output ⁴ HP/kW@rpm	59 / 42.9 @ 2500	59 / 42.9 @ 2500	59 / 42.9 @ 2500	59 / 42.9 @ 2500
			Torque ⁴ Lb-ft/Nm@rpm	130 / 176 @ 1600	130 / 176 @ 1600	130 / 176 @ 1600	130 / 176 @ 1600
	52		Speed, max governed rpm	2650	2650	2650	2650
	53		Cylinders/displacement cu. in.-liters	4 / 171 - 2.8	4 / 171 - 2.8	4 / 171 - 2.8	4 / 171 - 2.8
	54	Transmission	Manufacturer/type, speeds F/R	Clark/Powershift, 1/1	Clark/Powershift, 1/1	Clark/Powershift, 1/1	Clark/Powershift, 1/1
57	Hydraulic pressure	For attachments PSI/Bar	Adjustable	Adjustable	Adjustable	Adjustable	
58	Sound level	Avg. at operator's ear per ISO dB(A)	79	79	79	79	

Notes: 1 Weights and performance information are given on trucks with 189 in. (4800 mm) triple uprights (182 in (4625 mm) on C35).
2 Performance information shown for LPG.
3 Engines rated per SAE J1349.

CLARK GEN2 SERIES pneumatic tire trucks are designed for applications in manufacturing, warehousing and distribution. The standard design features provide high levels of operator comfort, reliability, ease of service and low noise to meet the most demanding operations.

Operator Control & Comfort

Gen2 Series trucks feature a rubber isolated operator cell that provides a quiet, comfortable and spacious environment for operators of all sizes. The large floor area is free of obstructions, easily removable without tools and covered with a thick, molded floormat. Large open steps and grab handles assist entry and exit from both sides. Two-pedal inch-brake system has low height, short travel pedals. Left pedal is for inching and brake operation; right pedal is for brakes only. Left foot actuated parking brake.

Hydraulic control levers are cowl-mounted. Left hand fingertip operated directional control is electrically actuated. Equipped with a legendary CLARK safety seat with shoulder restraints, adjustable and fold-down back rest, molded bolsters for comfort and support, six inches (150 mm) fore/aft adjustment, a retractable seat belt and an operator manual in the seat pocket. Visual and audio seat belt prompt on start-up. Tilt steering column locks in one of six positions; 38° total travel. Small, thick section wheel, with four turns lock-to-lock, is easily operated with one hand. Clamshell hood with gas struts gives easy access for daily inspections.

Instrument Panel

The instrument panel features a full LED/digital display with visual and audible engine monitoring warnings. Functions being monitored include water temperature, engine oil pressure, transmission oil temperature, alternator charge light, and low fuel. It also features fuel system diagnostics with indicator, programmable maintenance timer and touch pad light switches, hour meter, neutral start system and anti-restart. An automatic engine shutdown system continuously monitors engine oil pressure, engine coolant temperature and transmission oil temperature. The instrument panel includes prompts for the seat belt, parking brake, ignition key, headlights, instrument panel service engine light and is warranted for 2 years or 4,000 hours.

Engine

Mitsubishi model 4G64, 2.4-liter (143 Ci) 4-cylinder overhead cam engine with internal dynamic balancers and an LPG or gasoline fuel system. Camshaft and balancers are cog belt driven. Cast iron deep skirt block with aluminum cylinder head, 5-main bearing crankshaft.

Hydraulic valve lifters and electronic ignition reduce maintenance requirements. IMPCO LPG fuel systems are used with brackets for 33.5 lb. (15.2 kg) or 43.5 lb. (19.7 kg) tanks.

Yanmar model 4TNE94 2.8-Liter (171 C.I.) 4-cylinder Diesel engine. Vertical exhaust and a high volume hydraulic pump is standard on Diesel.

Engine Accessories/Capacities

Trucks are 12-volt negative ground and incorporate a heavy-duty starter. Batteries are rated at 550 CCA on LPG, 700 CCA on Diesel at 0° F (-18° C). High capacity air cleaners with raised air intake, automatic dirt ejectors and monitor indication for service. An optional air cleaner safety element and pre-cleaner can be added without other changes. A fuse panel with blade type fuses and relays is conveniently located. Moisture resistant electrical connectors and fusible links are located outside of harness for ease of access. Filters are easily serviced and located to prevent spillage. Crankcase capacity is 4.0 qts. (3.8 L).

Transaxle

Clark model TA 30, full reversing, single speed powershift transaxle with high stall ratio industrial torque converter, full-floating drive axles, and drum/shoe brake assemblies. Solenoid actuated, hydraulically modulated directional control and mechanically actuated, hydraulic inching. Helical drive gears operate smoothly and reduce noise. The gear-driven hydraulic pump is transmission mounted. Control elements and test ports readily accessible for service. Heavy-duty transmission cooler, mounted integral in a high efficiency, open core radiator, provides independent transmission cooling. The full-flow transmission spin-on oil filter and sump screen are easily serviced.

Brakes

Self-energizing, hydraulically-actuated drum and shoe type service brakes. Shrouds prevent dirt entry into the brake area. Inching and brake operation with left pedal, braking only with right pedal. Heavy backing plates, brake shoes, and drums with openings for inspection and adjustment; all components asbestos-free. Brakes are self-adjusting and quickly accessed by removing wheel and brake drum; no axle removal is required. Use of the parking brake, with electric transmission interrupt, prevents driving against the brakes. Left foot parking brake pedal actuates service brakes at both drive wheels. A dual stage master cylinder assures smooth braking and reduced pedal effort with short pedal stroke.

Hydraulics

Single gear pump provides fluid for hydraulic functions and steering. Priority-demand steering system conserves energy by supplying hydraulic fluid on demand-only basis. Hydraulic tank is integral with truck frame. An in-tank return line filter is quickly changed without spill. A quick-connect pressure port on the pump enables convenient pressure checks. All pressure fittings utilize O-ring face seals for leak-free operation. Sump tank capacity is 8.0 gal. (30.2 L).

Steering

Full hydrostatic steering. A compact axle beam with an integral double acting steer cylinder. Spindle assemblies incorporate king pins with tapered roller bearings to provide a rugged yet easily serviced assembly. Rubber isolation mounts supporting the axle absorb shock and reduce noise. Metal shields protect spindle bearing seals from wire or in-plant debris. Grease fittings extend linkage and bearing service life.

Upright

High visibility standard, Hi-Lo, triple stage and Quad uprights of heavy C-channel outer rails and full I-section inner and intermediate rails. A wide range of lift heights are available. All-roller operation of upright rails and carriage. Rollers are canted to accept both normal and side thrust loads. The ITA Class II and III carriages employ six main rollers with two inner and two outer thrust rollers to absorb off-center loading. Load backrest is designed for optimum visibility. Hydraulic cushioning between stages aids in smooth and quiet operation. Self-lubricating trunnion bushings and simplified roller access improve serviceability. Hydraulic tilt lock valve prevents improper tilt cylinder operation; integral flow limiting valves prevent rapid carriage descent in the event of a line failure; and a lowering control valve allows faster lowering speeds when empty or with light loads.

Additional Features

A single auxiliary valve and two headlights mounted on the overhead guard are standard equipment. The auxiliary hydraulic flow can be easily adjusted at the main valve to match the flow requirements of different attachments. With a one-piece hood and quickly removable floorplate, all routine maintenance checkpoints are readily accessible. The operator cell is designed for operator comfort and productivity. The Operator Manual is permanently attached inside the rear pocket of the comfortable safety seat. Color is high visibility Clark Green with non-glare matte black trim and white wheels. Tow pin in the counterweight and rear tie-downs are standard.

Notes

Production engines and driveline components may vary in output and/or efficiency by ±5%. The performance shown represents nominal values which may be obtained under typical operating conditions of a machine.

Clark products and specifications are subject to change without notice.

© Clark Material Handling Company 2005.

ANSI and Insurance Classification

Standard truck meets all applicable mandatory requirements of ANSI-B56.1 Safety Standard for Powered Industrial Trucks and Underwriters Laboratories requirements as to fire hazard only for LP and LPS classifications. For further information contact a Clark representative.

 **North America CMHC**
Worldwide Headquarters
700 Enterprise Drive
Lexington, KY 40510
866-252-5275
www.clarkmhc.com

your authorized CLARK dealer is: